

TROWEL MACHINE

46" (1200mm)



MBW INC.

COMPACTION & CONCRETE
CONSTRUCTION EQUIPMENT



POWERED by
HONDA



MBW 46" Professional Trowel Machine

MBW walk behind trowel machines are heavy-duty, USA built machines for the professional contractor. It starts with the over engineered cast alloy gearbox with cooling fins to ensure rapid heat dissipation for extended bearing and lubricant life. Add the precision machined worm shaft, bronze gears, over engineered seals, and bearings make this gear box the most rugged gearbox in the industry.

Whilst being heavy duty, MBW doesn't sacrifice on operator comfort and usability. From the adjustable handle bars, the fully enclosed stop switch, anti vibration mounts and a teflon lined throttle cable for smooth and easy operation. The MBW trowel machine can also be upgraded with a high torque clutch and/or an EZ pitch handle for instant.

Comparison of these critical components to those of other machines answers the question as to why MBW trowel machines run so well for so long.



P: 1300 255 266

E: sales@allcongroup.com.au

W: allcongroup.com.au

TROWEL MACHINE

46" (1200mm)



MBW INC.

COMPACTION & CONCRETE
CONSTRUCTION EQUIPMENT

FEATURES

CAST ALUMINUM ALLOY HOUSING

Features reinforced construction and cooling fins for rapid heat dissipation

VERTICAL SHAFT ASSEMBLY

Has heavier flange & hubs for greater shaft support. Heavy duty high load capacity bearings add to gear box longevity.

WORM SHAFT ASSEMBLY

Precision machined from solid stock. Bearing journals are precision ground for proper fit and preservation of internal bearing tolerances.

TEFLON LINED INSERTS

The teflon lined steel bore inserts will not pound out causing alignment problems.

HEX TO BLADE MATING SURFACE

Blade arm is precision milled for near perfect blade alignment.

HEAVY CAST ENGAGEMENT YOKE

Wider and longer construction to increase life and control of the blade adjustment cable

PRESSURE PLATE ASSEMBLY

Plate assembly utilises greasable trust bearings to provide little or no RPM variation.

TILT ARM ASSEMBLY

Utilises the industry's heaviest material both in hex stock and larger diameter machined ends.

SPIDER ASSEMBLY

The spider assembly is 15% heavier than competitive models with thicker walls around all bores. Industrial grade 45° grease fittings and hardware throughout machine ensures long life.

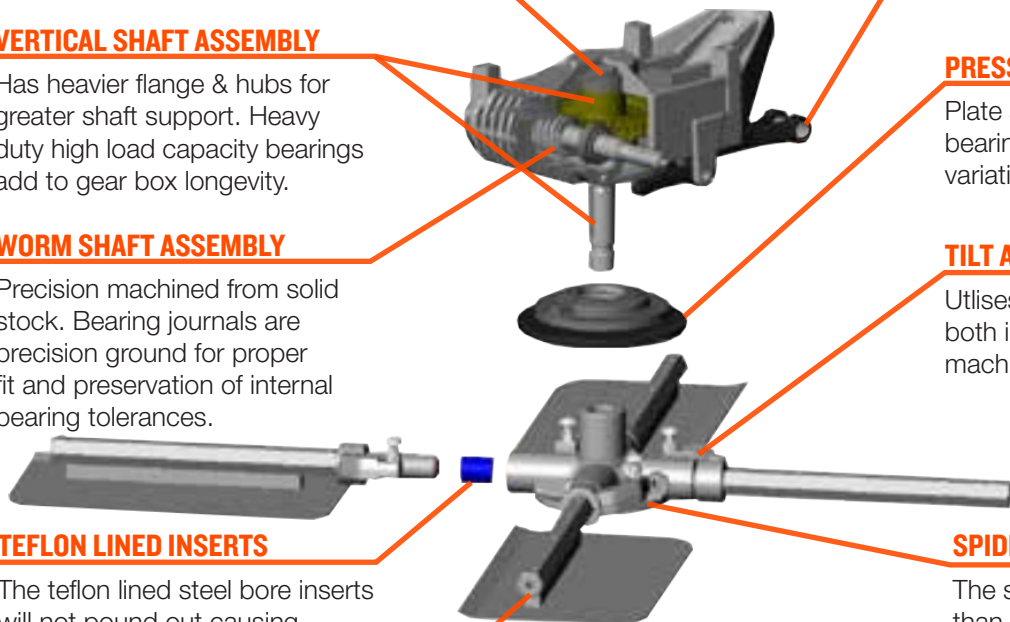

HEAVY DUTY RING CONSTRUCTION

ISO Compliant, low profile guard ring allows for easy cleaning and blade changes.



ADJUSTABLE HANDLE

Tool free adjustable handle for operator comfort and control



P: 1300 255 266

E: sales@allcongroup.com.au

W: allcongroup.com.au

TROWEL MACHINE

46" (1200mm)



MBW INC.

COMPACTION & CONCRETE
CONSTRUCTION EQUIPMENT

OPTIONAL EXTRAS



EZ PITCH™ HANDLE

Quickly and effortlessly adjust the blade pitch with thanks to the constant force gas spring mechanism. Can be retrofitted to older MBW trowels as a complete assembly.



LOW VIBE HANDLE

Patented low vibration handle to reduce operator fatigue. Can be retrofitted to older MBW trowels as a complete assembly.



HIGH TORQUE CLUTCH

High torque clutches provide consistent torque over the entire speed range giving you ultimate control over the trowel speed.

MBW 46" TROWEL SPECIFICATIONS

Model	M46270	M46390
Ring Diameter	47.6" (1210mm)	
Blade Sweep	46" (1170mm)	
Engine	Honda GX270	Honda GX390
Weight	112kg	118kg
Rotor Speed	70-135 RPM with standard clutch 35-180 RPM with high torque clutch	
Blades	4 x 46" (TBB46C, TBB46F)	

ABOUT MBW

Since 1967, MBW has been manufacturing one of the construction industry's most interesting lines of compaction, concrete and related equipment.

What makes the MBW line interesting?

MBW is not a copyist - we do not duplicate designs developed by others. MBW begins each new engineering project with the assumption that significant progress can be made in terms of improved productivity, reduced maintenance, longer life, enhanced user safety and lower long-term cost of ownership. Often MBW's R&D efforts result in entirely fresh approaches to solving industry problems, increasing productivity and producing the industry's safest tools.



P: 1300 255 266

E: sales@allcongroup.com.au

W: allcongroup.com.au